

SIL Inline Single Stage Centrifugal Pumps



SIL Inline Pump Range – True Reliability

Sulzer's new inline pump range (SIL) has been designed to fulfill efficiency regulations across all industries and also the design requirements of the ISO 5199 international standard. Inline design with integrated motor construction makes the pump compact and easy to install reducing the total cost of ownership.

Main Applications

The SIL pump range has been designed to meet the process requirements in versatile general and industrial applications to pump

- clean and slightly contaminated liquids
- viscous liquids up to 250 cSt
- fibrous slurries up to 1% consistency

Key Customer Benefits

The SIL pump range has been designed using our long experience and in-depth knowledge of how to maximize value for our customers.

Key benefits include:

Premium efficiency

- The inline pump exceeds the EU's (European Union) requirements for energy-related products (ErP)
- The whole pump range exceeds MEI 0.4 (Minimum Efficiency Index)

First class reliability

- The pump construction is optimized for clean liquid applications to maximize the lifetime of the pump
- Monoblock construction means compact, rigid and reliable design eliminating the need for a bearing unit. This minimizes the wearing parts and need for maintenance.
- Optimized shaft seal chamber and balancing holes guarantee improved conditions for the shaft seal maximizing its life time

Minimized total cost of ownership (TCO)

- Low energy consumption due to high efficiency
- Low operational costs, low spare parts costs and minimized service due to trouble-free monoblock construction
- Low installation and maintenance costs due to easy installation and simple design

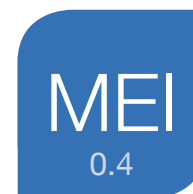
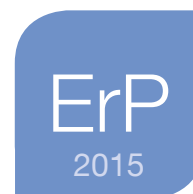

SIL Inline Single Stage Centrifugal Pumps



Oil and gas



Hydrocarbon processing



Power generation



Pulp and paper



General industry



Chemical process industry



Water and wastewater

Operating data

50 Hz	Capacities	60 Hz
up to 720 m ³ /h		up to 3,200 USgpm
up to 100 m	Heads	up to 328 ft
up to 16 bar	Pressures	up to 230 psi
up to 180°C	Temperatures	up to 356°F
up to 3,600 rpm	Maximum speed of rotation	up to 3,600 rpm

Performance ranges

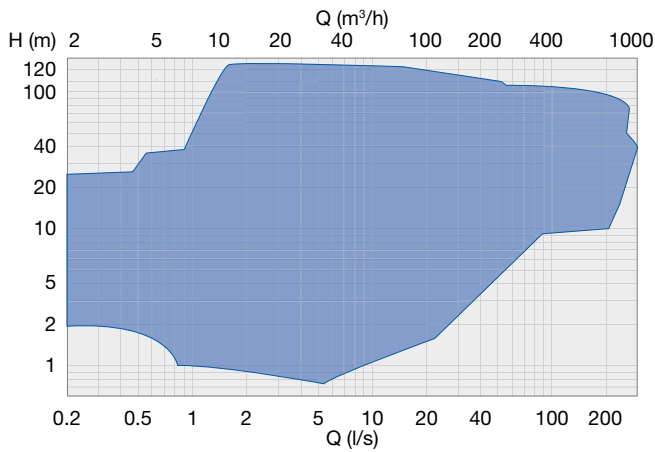

With integrated motor

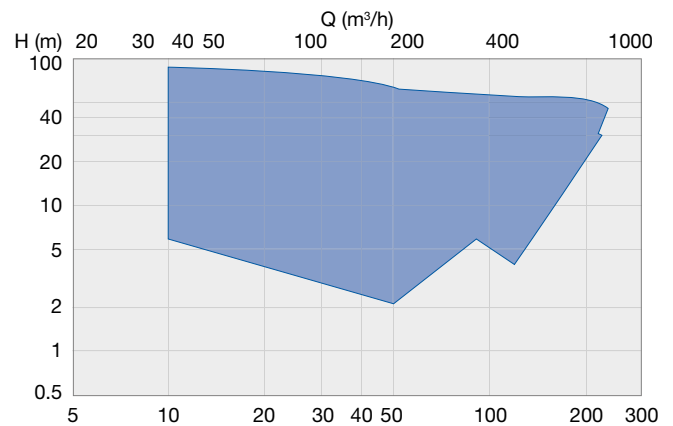

With IEC motor

Premium Efficiency and Monoblock Construction Improve Reliability and Minimize Total Cost of Ownership

1 Simple, compact and heavy duty monoblock construction

- No bearing unit – no maintenance of bearings needed minimizing maintenance costs
- Rigid construction with short shaft minimizes vibrations maximizing pump and seal lifetime
- Reduces maintenance and spare parts costs

2 Rigid, high efficiency, low NPSHr (Net Positive Suction Head required) impeller

- Reduced total cost of ownership, especially energy consumption and operational downtime costs

3 Classic keyway impeller mounting

- Long support between the shaft and impeller minimizes vibration
- Enables easy and quick dismantling and reassembly
- Minimizes maintenance costs

4 Large variety of mechanical shaft seals

- Single and double mechanical seals
- Reliable and trouble-free operation
- Easy and quick assembly and dismantling
- Reduces total cost of ownership by minimizing maintenance and downtime costs

5 Optimized sealing lubrication

- Large bore seal chamber and impeller balancing holes guarantee the right flow and pressure in the shaft sealing area
- Improves seal life time, reduces unexpected shutdowns and minimizes maintenance costs

6 High efficiency integrated low voltage motors

- Large power range available
- IE3 efficiency class available
- Suitable for frequency converter use
- Impeller mounting directly onto motor shaft
- Reduces total cost of ownership by minimizing energy consumption

7 Quick and easy installation

- Can be installed without a base plate between the piping depending on the motor size
- SIL pumps with integrated motor can be installed both vertically and horizontally on the basis of the piping arrangement
- No need for base plate grouting
- No need for motor/pump alignment
- Needs small space due to compact design
- Reduces total cost of ownership by minimizing installation costs

8 Highly standardized pump design

- Minimizes spare parts inventory and saves maintenance costs



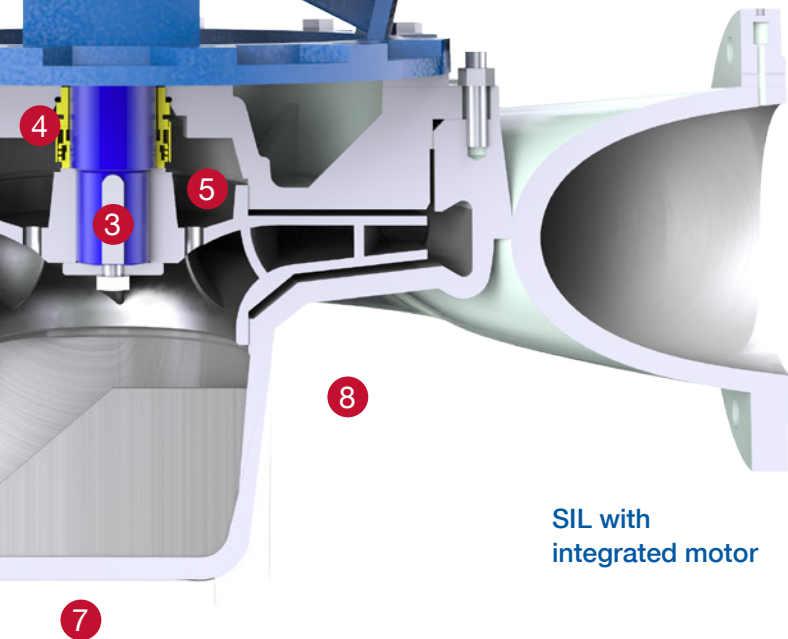
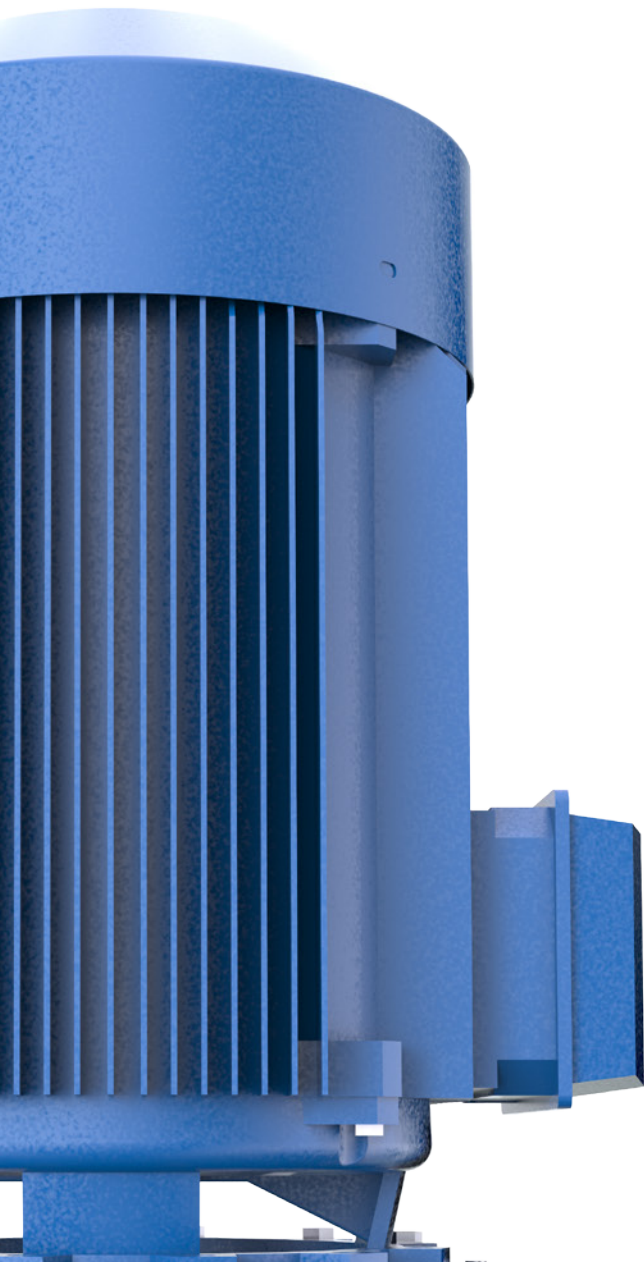

SIL with integrated motor

9 SIL with high efficiency IEC standard motor

- The motor is installed to the pump with an adapter
- The motors are flange mounted IEC standard motors
- Large power range available
- IE2, IE3 and IE4 efficiency classes available
- Suitable for frequency converter use
- Impeller mounting onto a flange shaft which is connected to the motor shaft with a coupling
- Reduces total cost of ownership by minimizing energy consumption

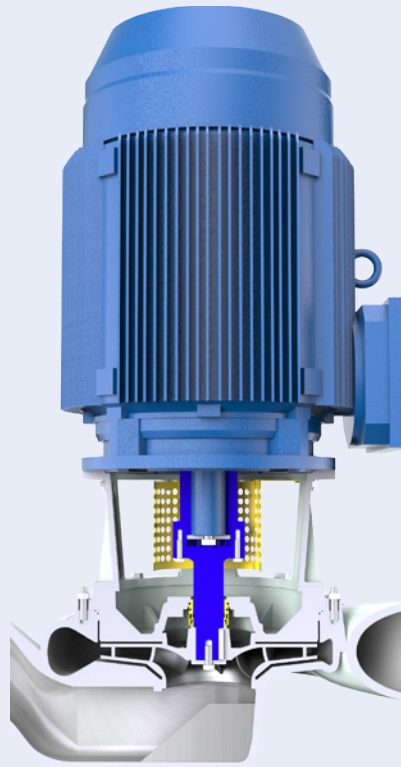

SIL with IEC standard motor

High Efficiency across the Whole Pump Range, Exceeding MEI 0.4

Energy efficiency is a hot topic in industry. So important that the European Union (EU) has created ErP (Energy-related Products) regulations specifying minimum efficiency values for water pumps, with the target of reducing energy consumption. From now on, only pumps and motors which satisfy the energy efficiency requirements of the EU's ErP Directive may be sold.

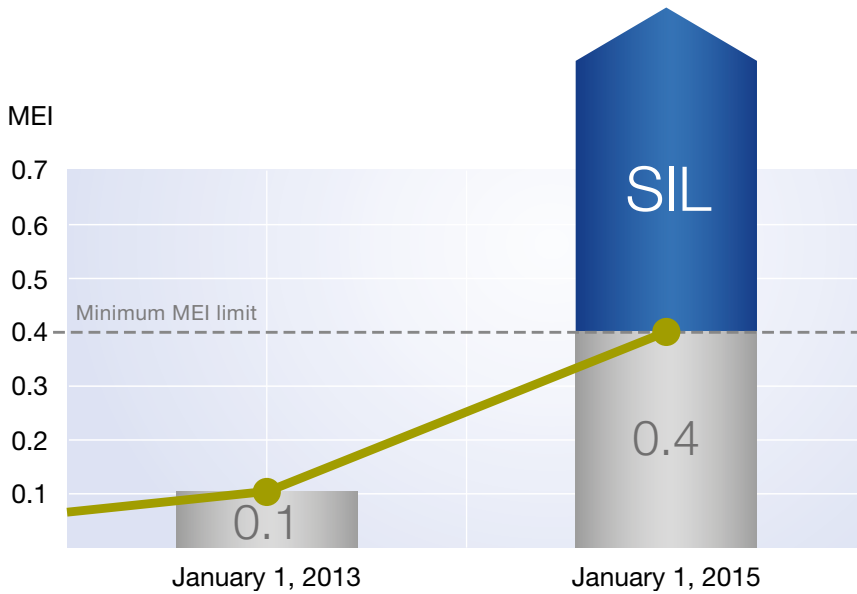

MEI, the minimum efficiency index for standardized water pumps, was set up to be ≥ 0.4 since the beginning of 2015. This means that at present 40% of the pumps on the market do not comply.

Sulzer's SIL pump range fulfills the requirements of ErP and the requirements of all other industrial efficiency regulations.

Materials

Standard material options	Material		
Cast Iron	ASTM	A48 CL30	ENGJL200
Ductile Iron	ASTM	A536	ENGJS400
Austenitic	ASTM	A743	Grade CF-8M
Austenitic	ASTM	S31254	SS2378 254 SMO
Duplex SS	ASTM	A890	Grade 3A
Bronze	ASTM	B505	CuSn10Zn2

Impeller

The efficiency, stability and reliability of the pump are based on the design. The impeller is designed in tandem with the casing and seal chamber. The result is efficient hydraulics with reliable shaft sealing ensuring higher reliability. The closed impeller is designed to suit versatile liquids maximizing standardization and minimizing the need for spare parts.

Design

- Closed impeller for clean and slightly contaminated liquids
- High efficiency
- Low net positive suction head required (NPSHr)
- Sturdy and strong design
- Optimized balancing holes

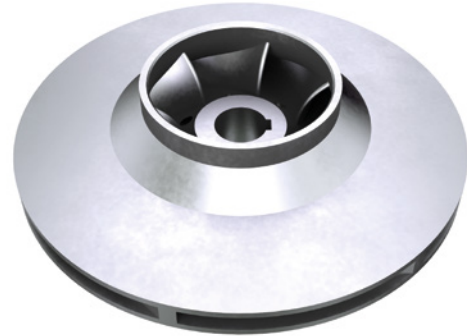

Impeller balancing holes guarantee optimized flow and pressure in the shaft sealing area

- Dry running of the single mechanical seal is eliminated across a wide operating area
- Increased reliability and lower downtime and maintenance costs

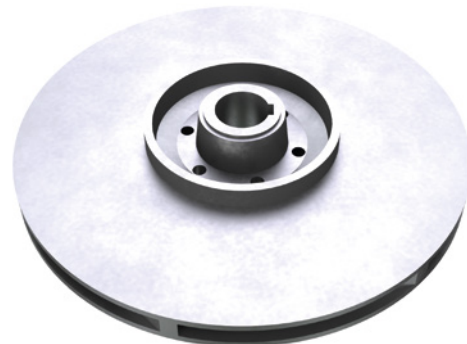

Keyway impeller mounting

- Easy and quick dismantling and assembly
- Allows reverse rotation
- Minimizes downtime and maintenance costs

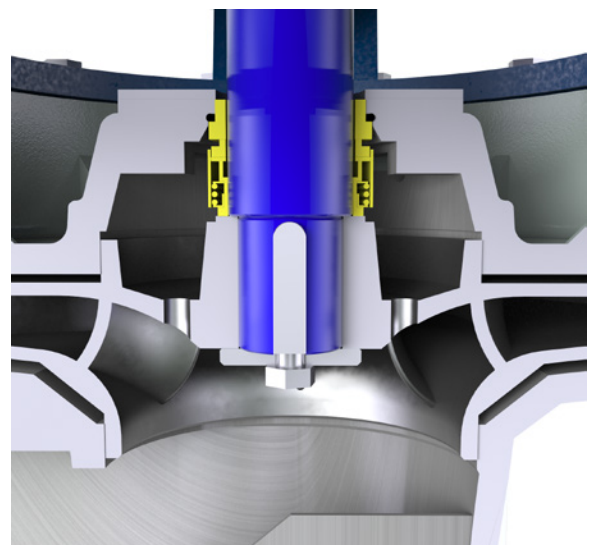

Shaft Seals

Large variety of mechanical shaft seals for maximizing operational reliability and minimizing downtime costs.

The shaft seal is selected according to the application to ensure reliable shaft sealing. A large bore seal chamber guarantees optimal conditions and good lubrication for the seal faces.

There is a large variety of shaft seals to fulfill the needs of various pumping conditions. Mechanical seals are installed directly on the shaft and are easy and fast to install.

Single mechanical seal

- Positive inlet pressure is required
- The seal faces are lubricated by the pumped liquid flowing through the impeller balancing holes into the seal chamber
- Suitable for clean and slightly contaminated liquids
- Temperature 10°C / 20°F below the boiling point of the pumped liquid at atmospheric pressure, max. 120°C / 250°F

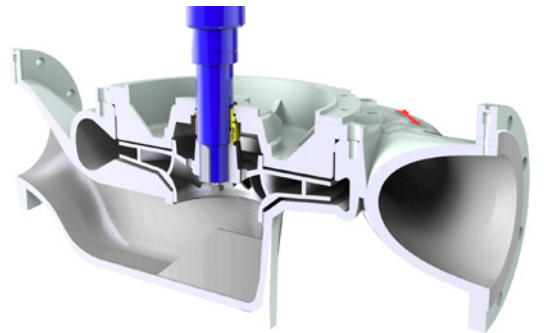

Single mechanical seal with recirculation flushing

- The seal faces are lubricated by the pumped liquid circulated through a pipe from the discharge pipe into the seal chamber
- Suitable for clean liquids, water and condensates
- Temperatures up to 150°C / 300°F

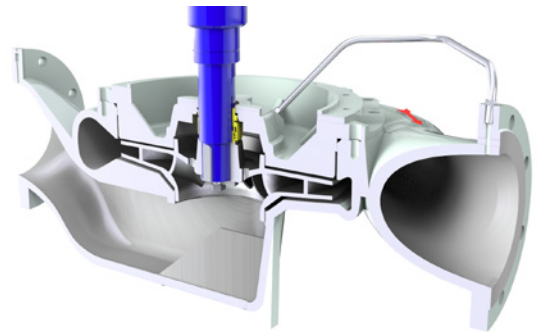

Single mechanical seal with external clean flushing

- The seal faces are lubricated by external clean flushing liquid fed through a pipe from an external source into the seal chamber
- Suitable for clean and slightly contaminated liquids as well as viscous liquids
- External flushing is mixed into the pumped liquid
- Temperatures up to 180°C / 356°F

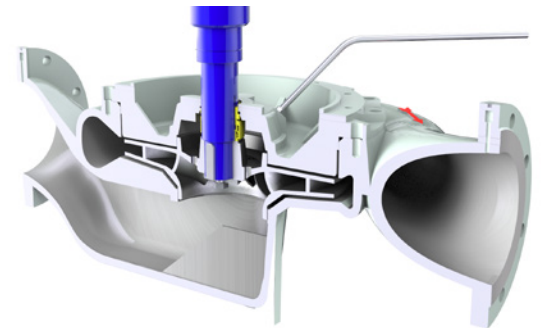

Double mechanical seal with external sealing liquid

- The seal faces are lubricated by non-pressurized (quench) or pressurized (barrier) external clean sealing liquid fed through a pipe from an external source into the seal between the seal face pairs
- Designed for clean and slightly contaminated liquids as well as viscous liquids
- Temperatures up to 180°C / 356°F

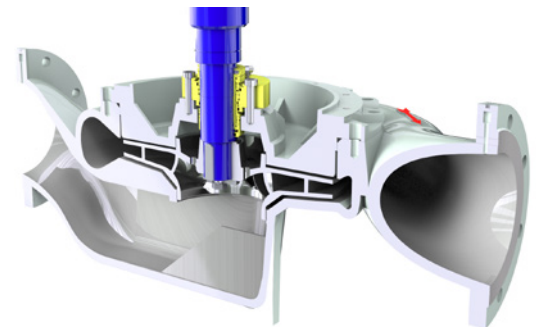

Sealing Water Equipment

Sealing water equipment regulates the volume and pressure of external sealing water for optimum shaft seal performance. The equipment is attached directly to the supply connection using a hose.

Sealing water equipment for external flushing

- Single mechanical seals
- The pressure of incoming water supply must be at least 0.5 bar / 7 psi higher than the pressure in the seal chamber
- The volume of sealing water can be regulated by the control valve on the sealing water equipment, typical value is 3 l/min / 0.8 USgpm

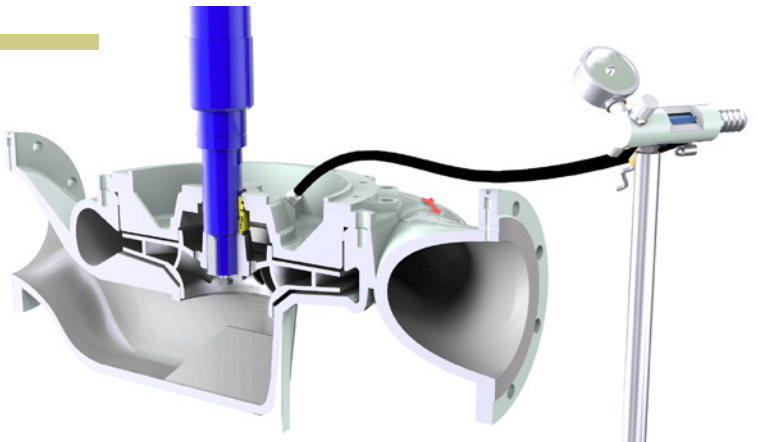

Sealing water equipment for non-pressurized (quench) sealing water

- Double mechanical seals
- The pressure of incoming water supply must be positive
- The volume of sealing water can be regulated by the control valve on the sealing water equipment, typical value is 3 l/min / 0.8 USgpm

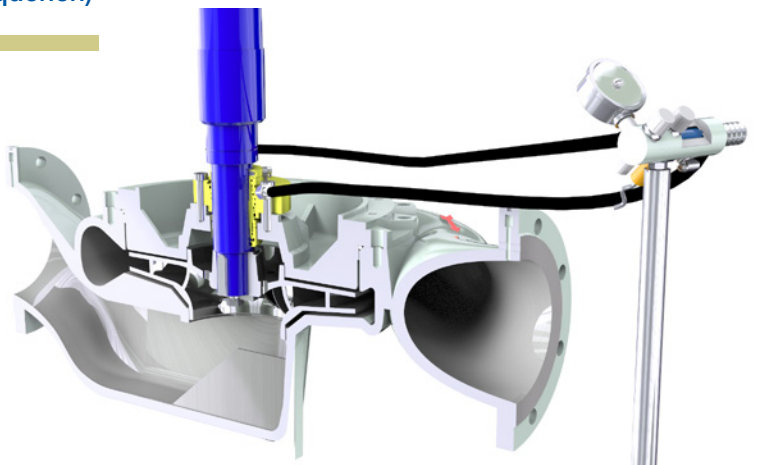

Sealing water equipment for pressurized sealing water

- Double mechanical seals
- The pressure of incoming water supply must be at least 0.5 bar / 7 psi higher than the pressure in the seal chamber
- The volume and pressure of sealing water can be regulated by the control valve on the sealing water equipment, typical value is 3 l/min / 0.8 USgpm

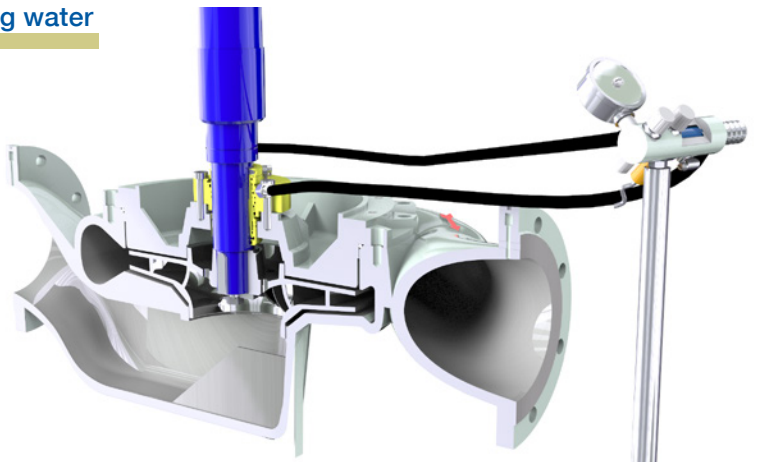

Drive motor

SIL pumps are of a monoblock construction. They are equipped either with an integrated AC motor or with an IEC standard motor.

Integrated motor construction

- The motor is integrated into the pump
- The impeller is installed directly onto the motor shaft without any coupling
- Available efficiency grades IE3
- Available power range 0.05 - 160 kW
- Available in 2-pole and 4-pole models
- The motor is VFD compatible
- The pump and motor combination is very compact and quick to install
- Pumps equipped with a max. 15 kW motor can be installed between the pipes without additional support or base plate

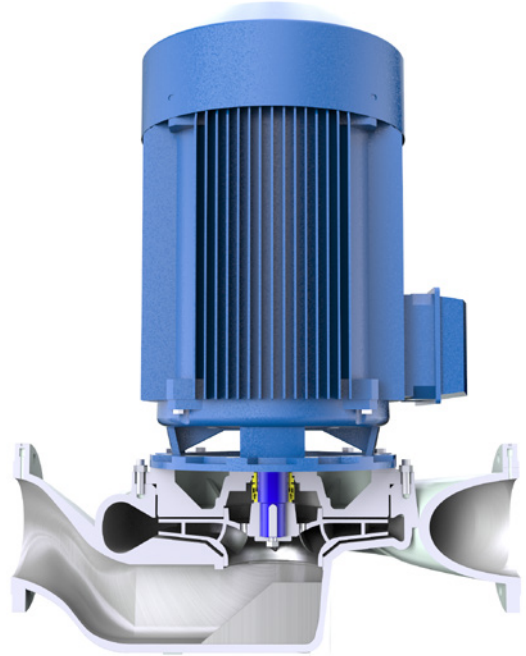

IEC standard motor construction

- The motor is an IEC standard low voltage flange mounted AC-motor
- The motor is installed to the pump with an adapter
- The impeller is installed to a flange shaft which is connected to the motor shaft with a coupling
- Available efficiency grades IE2, IE3, IE4
- Available power range 4 - 110 kW
- Available in 2-pole and 4-pole models
- The motor is VFD compatible
- The pump and motor combination is compact and quick to install

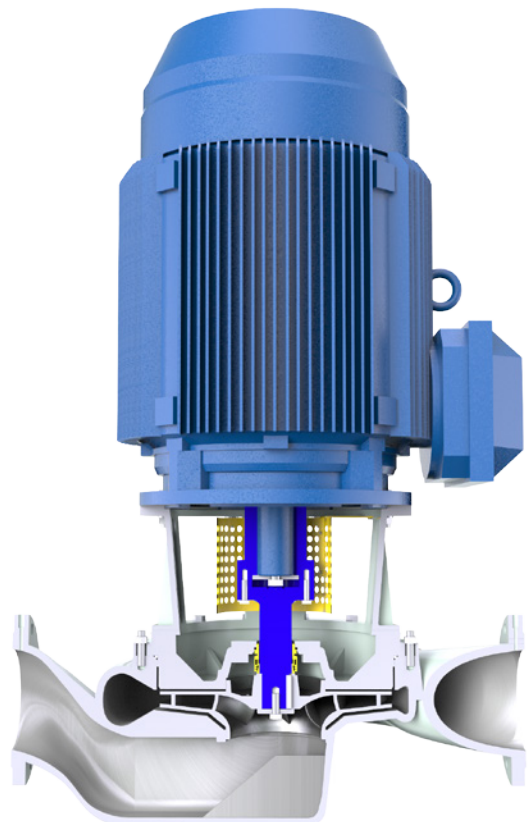

Key Design Features - Installation, Operation and Maintenance

- 1** SIL pumps with integrated motor <15 kW can be installed between the pipes without additional support or base plate
 - Easy and fast to install minimizing installation costs
 - Vertical and horizontal installation is allowed
- 2** Steel base plate installed onto a free moving concrete plinth
 - For pumps equipped with integrated motor > 15 kW and all IEC motor versions
 - Easy and fast to install minimizing installation costs
- 3** Monoblock construction
 - No need for additional bearing unit
 - No need for coupling alignment
 - Needs minimized installation space for the pump and motor
 - Minimizes installation and maintenance costs and also ensures safe and reliable operation
- 4** Coupling guards for the rotating parts are designed according to stringent safety regulations
 - Ensures safe and reliable operation
- 5** Back pull-out design facilitates quick access for servicing without detaching the pump from the piping





www.sulzer.com

E10385 en 10.2016 (2,000), Copyright © Sulzer Ltd 2016

This brochure is a general presentation. It does not provide any warranty or guarantee of any kind. Please, contact us for a description of the warranties and guarantees offered with our products. Directions for use and safety will be given separately. All information herein is subject to change without notice.